

PIETRANERA S.p.a.

Via Mancasale, 2 - Z.I. Mancasale - 42100 Reggio Emilia (Italy)

Tel. +39.0522.516510 - Fax +39.0522.514669

E-mail: info@pietranera.com

No.ordine / Order / Commande / Pedido:

Data / Date / Date / Fecha:

No.articoli / No.article / Piece / Artículo:

Data consegna/ Delivery / Livraison / Entrega:

Colore 1 / Colour 1 / Couleur 1 / Color 1

Cod:

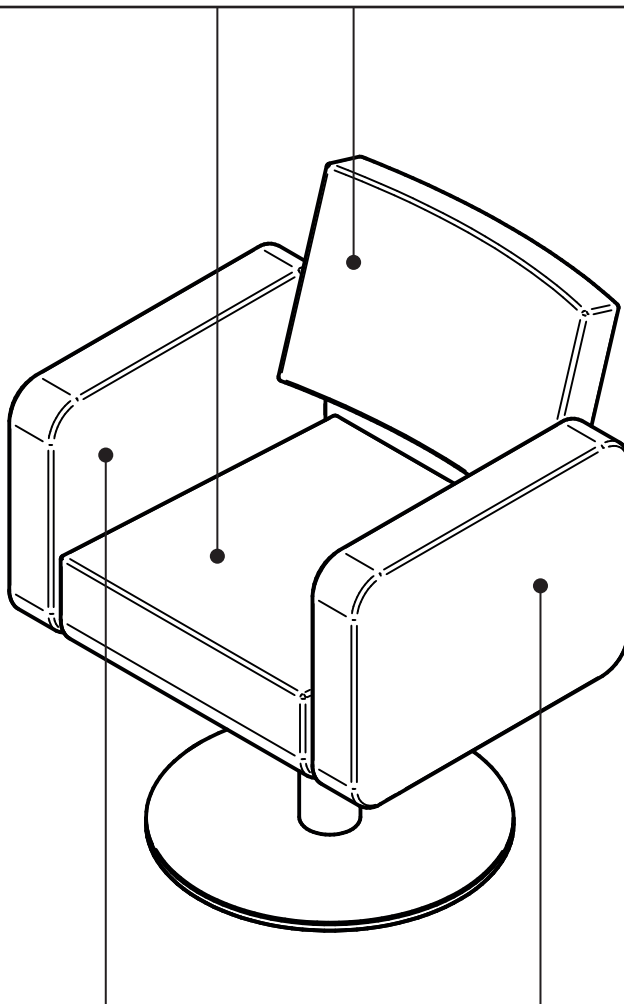

Colore 2 / Colour 2 / Couleur 2 / Color 2

Cod:

Note/ Note :